



SERVICE MANUAL

COLOUR CCD Camera

VCC-9615P

(Product Code : 117 047 15)
(Europe)

SPECIFICATIONS

TV system : PAL standard (625 TV lines, 25 frames/sec.)
Scanning system : 625 TV lines, 50 field/sec., 2:1 interlace
Image device : Interline transfer method, 1/3 inch solid state CCD
Picture elements : 795 (Horizontal) x 596 (Vertical)
Effective picture elements : 752 (Horizontal) x 582 (Vertical)
Synchronization system : Internal sync.
Resolution : 480 TV lines horizontally, 400 TV lines vertically
Video output signal level : 1.0 Vp-p/75 Ω (screw-on terminal)
S/N ratio : More than 48 dB
Minimum required illumination : 1.8 lux (F 1.6 lens)
White balance : A (Automatic: TTL system)/M (Manual) manual switching
Backlight compensation : 1 (On)/0 (Off) manual switching,
Active-zone light measuring system
Backlight compensation iris level adjustment : Manual LEVEL volume control
Aperture : 1 (High)/0 (Normal) manual switching
Gain control : Automatic
MONITOR output pin : 1.0 Vp-p/75 Ω , test point pin
Lens : F1.6 ~ 2.3, f=2.6 ~ 6.0 mm, varifocal lens, manual zoom and focus adjustment
Iris system : Mechanical auto iris
Operational environmental conditions : Temperature: -10 °C ~ + 50 °C
Humidity: less than 90 %
Storage environmental conditions : Temperature: -20 °C ~ + 60 °C
Humidity: less than 70 %
Power supply : 12-15 V DC/ 24 V AC, 50 Hz
Power consumption : 3.5 W
Weight : Approx. 420 g

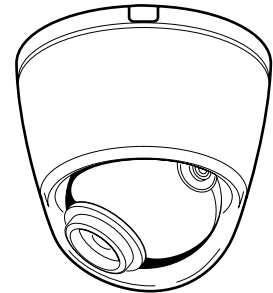

CONTENTS

1. DISASSEMBLY, VR AND TP LOCATION AND BOARD LOCATION	2
2. ADJUSTMENT	3
3. PARTS LIST	5
CIRCUIT DIAGRAM & PRINTED WIRING BOARDS	C1

PRODUCT SAFETY NOTICE

The components designated by a symbol (\triangle) in this schematic diagram designates components whose value are of special significance to product safety. Should any component designated by a symbol need to be replaced, use only the part designated in the Parts List. Do not deviate from the resistance, wattage, and voltage ratings shown.

NOTE : 1. Parts order must contain model number, part number, and description.
2. Substitute parts may be supplied as the service parts.
3. N. S. P. : Not available as service parts.

Design and specification are subject to change without notice.

1. DISASSEMBLY, VR AND TP LOCATION AND BOARD LOCATION

1. Dec window
2. Four screws 2 x 5
3. Four screws 2.6 x 4
4. Lid
5. Four screws 2 x 5
6. Two FPCs
7. Connector
8. CA2 board
9. Two screws 2 x 5
10. CA3 board
11. Two screws 3 x 8
12. Two Pipes
13. Two special washers
14. Cover front
15. Cover back
16. Food iris
17. Two screws 2 x 6
18. Connector
19. CA1 board

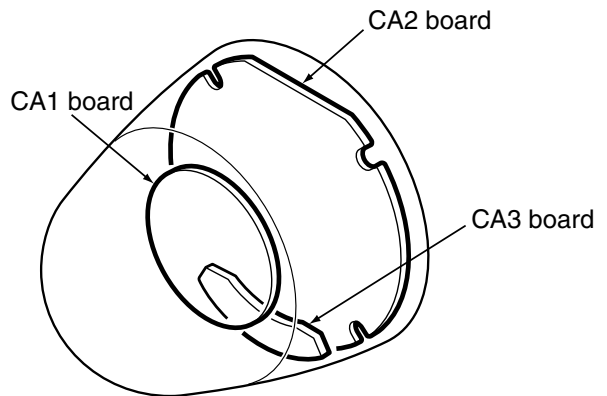
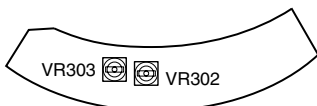
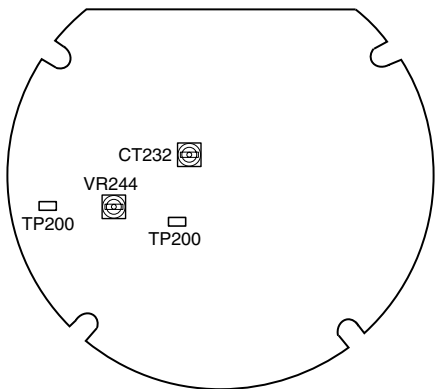
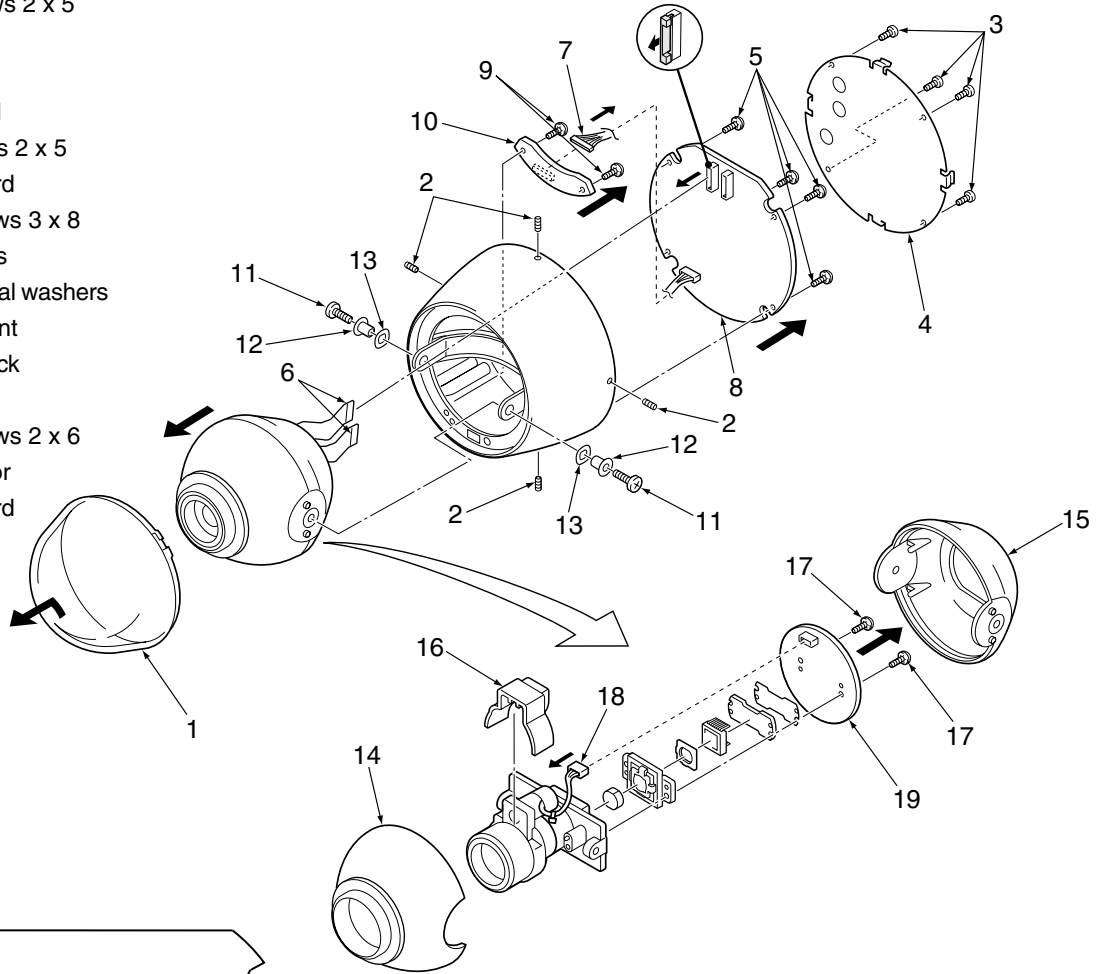

2. ADJUSTMENT

2-1. ADJUSTMENT CONDITION

1. Use the 5,100K viewer for the subject.
2. Set the trigger signal of oscilloscope to VIDEO OUT, and apply H sync unless specified.
3. Set S3001 (CA-3) to the all OFF position.
4. In adjustments without direction to display charts, shield light with a lens cap to provide dark condition.
5. Connect the video output to a video monitor with an input impedance of 75 Ω.
6. Ground test point is TP200 (CA-2).

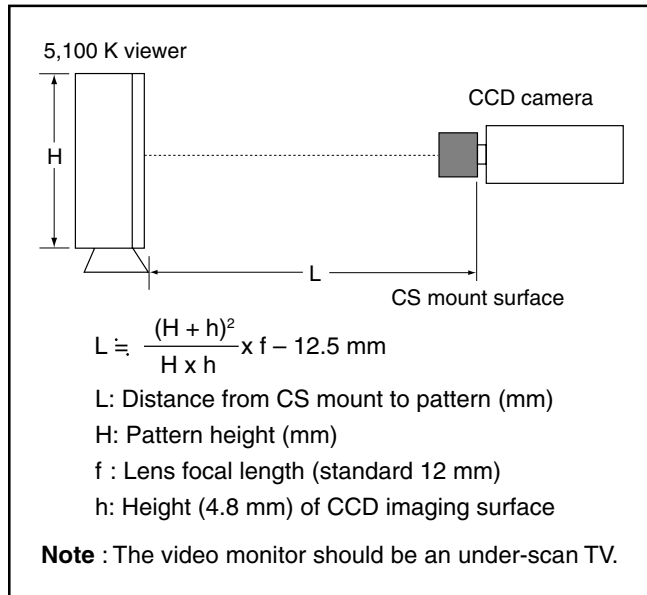

2-2. PREPARATION

1. Install the adjustment software (VHJ-0157) in a computer running the Windows operating system.
2. Use the adjustment tool (VHJ-0127) to connect the camera to be adjusted to the serial port of the computer with RS-232C cross cable, and then turn on the power for the computer and the camera.
3. Use COM1 serial port on the computer.

2-3. TABLE FOR SERVICING TOOLS

Ref. No.	Name	Part code
J-1	Color viewer	VJ8-0007
J-2	Adjustment jig	VHJ-0127
J-3	Calibration software	VHJ-0159
J-4	Chart for color adjustment	VJ8-0155

2-3-1. Computer screen during adjustment

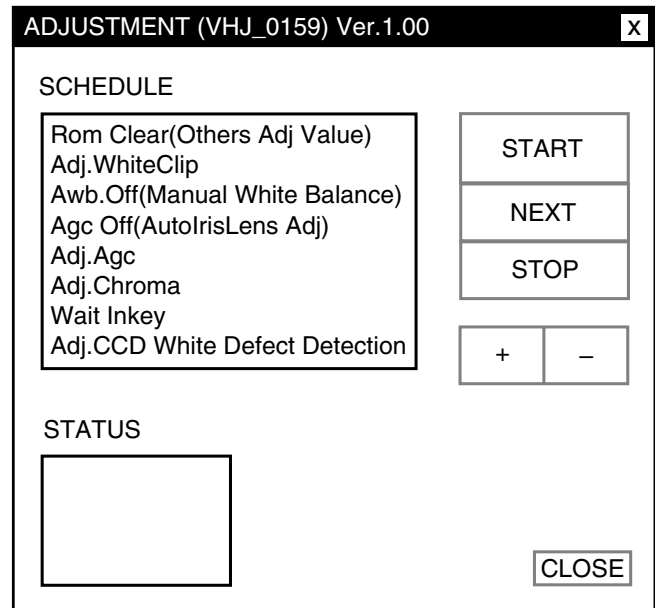

From 2-4. to 2-9. adjustments are continuous adjustment by adjustment software.

2-4. White Clip Adjustment

Adjustment location:

Measuring location: VIDEO OUT

Measuring equipment: Oscilloscope

Subject: No designation

Adjusting method:

1. Click the adjustment software installed from the personal computer, and the adjustment window will be displayed.
2. Click the start button. Rom clear to be white clip adjustment.
3. Display the viewer 2-10 μsec at the edge of the screen.
4. Adjust (+) and (-) button so that the adjustment value is 830 ± 10 mVp-p.

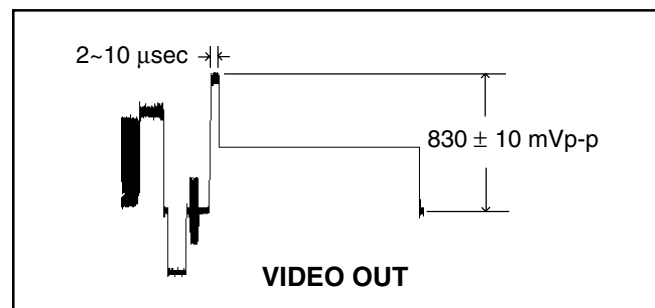

2-5. White Balance Adjustment

Adjustment location: VR302, VR303 (CA-3)

Measuring location: VIDEO OUT

Measuring equipment: Oscilloscope, Vectorscope

Subject: Color bar chart

Adjusting method:

1. Display the color bar chart at designated picture angle.
2. Click the "NEXT" button to be white balance adjustment.
3. Adjust VR302 and VR303 so that the luminescent spot representing white is overlapping with the crosshair mark in the center of the vectorscope.

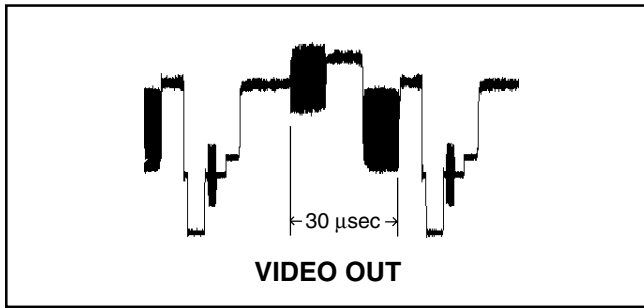

VIDEO OUT

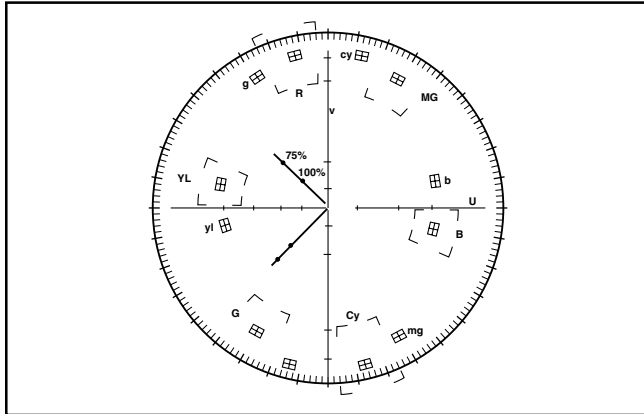

2-6. Iris Level Adjustment

Adjustment location: VR244 (CA-1)

Measuring location: VIDEO OUT

Measuring equipment: Oscilloscope, color bar chart

Subject: Gray scale chart

Adjusting method:

1. Display the color bar chart at designated picture angle.
2. Click the "NEXT" to be "Agc Off(AutoIrisLens Adj)" in the adjustment window.
3. Turn the VR244 to the right so that the white level is maximum.
4. Turn the VR244 to the left so that the output level is 550 ± 20 mVp-p.

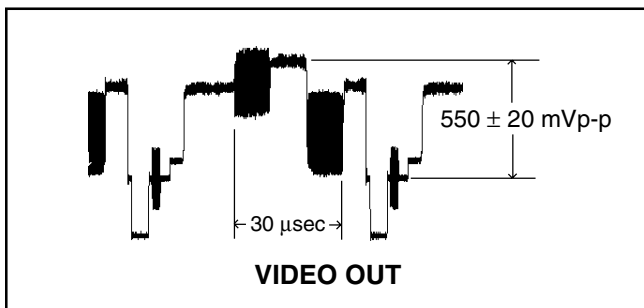

VIDEO OUT

2-7. AGC Level ADJUSTMENT

Adjustment location: Computer screen

Measuring location: VIDEO OUT

Measuring equipment: Oscilloscope, color bar chart

Subject: Gray scale chart

Adjusting method:

1. Display the color bar chart at designated picture angle.
2. Click the "NEXT" to be "Adj.Agc" in the adjustment window.

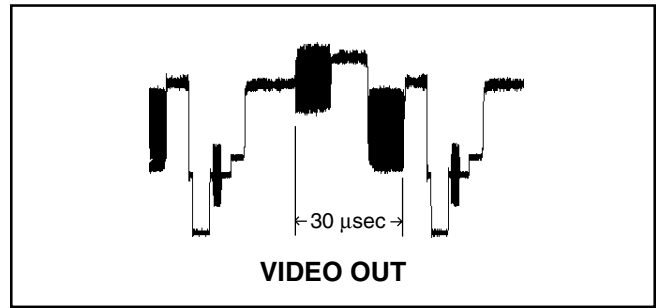

VIDEO OUT

After finishing AGC level adjustment, start Hue and chroma adjustment automatically.

2-8. Hue and Chroma Adjustment

Adjustment location: Computer screen

Measuring location: VIDEO OUT

Measuring equipment: Oscilloscope, vectorscope, color bar chart

Subject: Color bar chart (Display the color bar chart at designated picture angle.)

1. Adjust "Adj.Chroma" in the adjustment window.

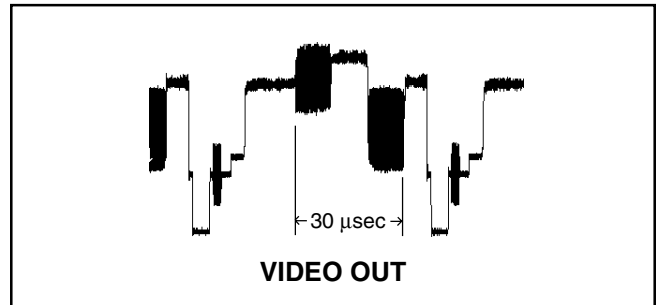

VIDEO OUT

2-9. CCD White Point Defect Detect Adjustment

Measuring location: VIDEO OUT

Measuring equipment: Monitor display

Adjustment method:

1. After finishing Hue and Chroma adjustment, shield light with a lens cap to provide dark condition.
2. Click the "NEXT" button to be CCD White Point Defect Detect Adjustment.
3. After completing this adjustment, it confirms that white point can not be seen on the monitor display.
4. "OK" will display in the "STATUS".
5. Click the "CLOSE" in the adjustment window, and complete the adjustment window.

2-10. 28 MHz VCO Voltage ADJUSTMENT

Adjustment location: CT232 (CA-2)

Measuring location: TP232 (CA-2)

Measuring equipment: Digital voltmeter

Subject: No designation

Adjusting method:

1. Adjust with CT232 to 6.0 ± 0.2 V.

3. PARTS LIST

LOCATION	PARTS NO.	DESCRIPTION
ACCESSORIES & PACKING MATERIALS		
9102	613 200 9003	INSTRUCTION MANUAL, English, French
9103	613 201 6414	INSTRUCTION MANUAL, German, Chinese
9201	411 073 6705	SCR TPG PAN 4X35
7001	613 200 8983	CARTON CASE INNER
7002	613 182 2375	CUSHION
7010	613 139 4896	P.E COVER

CABINET & CHASSIS PARTS

5005	636 044 4706	CABINET
5010	636 044 4980	DEC WINDOW
5015	636 052 2138	TERMINAL BASE
5016	636 029 7876	TERMINAL
5017	636 045 0059	EARTH
6005	613 179 1848	COVER FRONT
6006	613 179 1855	COVER BACK
6007	613 180 9376	HOOD LENS
6010	613 179 1862	OPTICAL BASE
6011	613 163 5258	SPACER
6012	613 194 2813	HOLDER CCD
6013	613 194 1199	SPACER INSULATOR
6014	613 179 6027	HOLDER CCD
6015	613 180 9383	HOOD IRIS

LOCATION	PARTS NO.	DESCRIPTION
6020	636 051 6236	ARM
6021	636 044 9213	ARMREST
6022	636 044 8278	SPRING PLATE
6023	613 179 3958	PIPE
6027	613 183 0349	EARTH
6028	613 201 3048	DEC PLATE
6030	636 045 5641	SPRING PLATE
6035	636 051 6243	LID
6050	636 070 7788	SHIELD TAPE EMC-SX591
8000	645 045 7654	ASSY, LENS
8001	645 002 7079	OPTICAL FILTER
8002	409 495 7400	IC ICX409AK-A, IC101
CA1	613 200 9324	COMPL PWB, CA-1
CA2	613 200 9331	COMPL PWB, CA-2
CA3	613 200 9348	COMPL PWB, CA-3
NJ506	411 163 1504	SCR SET 2X5
NJ510	411 122 1309	SCR BIN 3X6
NJ515	412 046 4704	SPECIAL SCREW-3.0X8.0
NJ600	411 129 5102	SCR PAN+SW+W 2X5
NJ615	411 158 9409	SCR PAN PCS 2.6X6
NJ620	411 002 5908	SCR PAN 2.6X4
NJ625	411 063 1307	SCR SET HEX-SCT 2.6X4
NJ630	411 001 9006	SCR BIN 3X8
NJ635	412 057 3802	SPECIAL WASHER 43X0.2
NJ640	411 030 7202	SCR BIN 2X6

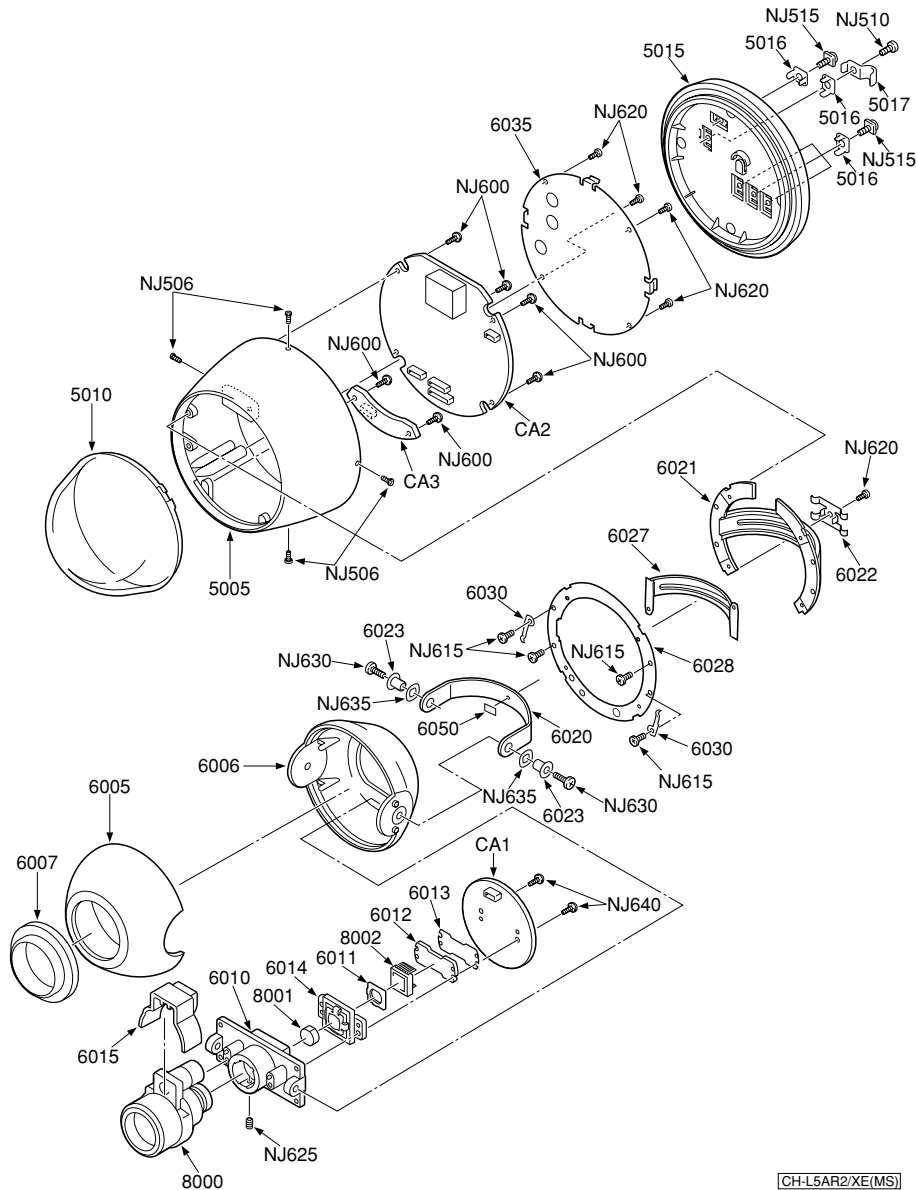

CH-L5AR2/XE(MS)

ELECTRICAL PARTS

Note:

1. Materials of Capacitors and Resistors are abbreviated as follows ;

Resistors

MT-FILM Metallized Film Resistor
MT-GLAZE Metallized Glaze Resistor
OXIDE-MT Oxide Metallized Film Resistor

Capacitors

MT-POLYEST Metallized Polyester Capacitor
MT-COMPO Metallized Composite Capacitor
TA-SOLID Tantalum Solid Capacitor
AL-SOLID Aluminum Solid Capacitor
NP-ELECT Non-Polarized Electrolytic Capacitor
OS-SOLID Aluminum Solid Capacitors with Organic Semiconductive Electrolytic Capacitor
DL-ELECT Double Layered Electrolytic Capacitor

2. Tolerance of Capacitor (10pF over) and Resistor are noted with follow symboles.

F1% G2% J5% K10%
M20% N30% Z+80% ~ -20%

3. Capacitors

U : µF P : pF

4. Inductors

UH : µH MH : mH

5. N.S.P. : Not available as service parts.

LOCATION	PARTS NO.	DESCRIPTION	LOCATION	PARTS NO.	DESCRIPTION
COMPL PWB,CA-1			COMPL PWB,CA-2		
	613 200 9324		R1013	401 224 9402	MT-GLAZE 1.0M JA 1/16W
			R1014	401 224 8900	MT-GLAZE 100K JA 1/16W
			R1015	401 225 8107	MT-GLAZE 10 JA 1/16W
			R1016	401 225 8107	MT-GLAZE 10 JA 1/16W
			R1017	401 224 8801	MT-GLAZE 100 JA 1/16W
			R1031	401 226 1503	MT-GLAZE 0.000 ZA 1/16W
			R1032	401 226 1503	MT-GLAZE 0.000 ZA 1/16W
			R1033	401 226 1503	MT-GLAZE 0.000 ZA 1/16W
			R1034	401 226 1503	MT-GLAZE 0.000 ZA 1/16W
			R1035	401 226 1503	MT-GLAZE 0.000 ZA 1/16W
			R1101	401 225 8107	MT-GLAZE 10 JA 1/16W
			R1102	401 224 8801	MT-GLAZE 100 JA 1/16W
			R1103	401 224 8801	MT-GLAZE 100 JA 1/16W
			R1104	401 224 8801	MT-GLAZE 100 JA 1/16W
			R1105	401 224 8801	MT-GLAZE 100 JA 1/16W
			R1106	401 224 8801	MT-GLAZE 100 JA 1/16W
			R1107	401 224 8801	MT-GLAZE 100 JA 1/16W
			R1108	401 224 8801	MT-GLAZE 100 JA 1/16W
			R1109	401 224 8801	MT-GLAZE 100 JA 1/16W
			R1110	401 224 8801	MT-GLAZE 100 JA 1/16W
			R1111	401 224 8801	MT-GLAZE 100 JA 1/16W
			(CONNECTORS)		
			CN101	645 060 3129	SOCKET,FFC 30P (N.S.P)
			CN102	645 060 3112	SOCKET,FFC 24P (N.S.P)
			CN121	645 023 0578	PLUG,4P (N.S.P)
			(SEMICONDUCTORS)		
			Q2121	405 014 4509	TR 2SC2412K-R
			Q2152	405 137 2000	TR 2SA1576A-R
			Q2154	405 092 4101	TR 2SC4081-R
			Q2161	405 092 4101	TR 2SC4081-R
			Q2165	405 137 2000	TR 2SA1576A-R
			Q2227	405 137 2000	TR 2SA1576A-R
			Q2231	405 137 2000	TR 2SA1576A-R
			Q2232	405 092 4101	TR 2SC4081-R
			Q2233	405 137 2000	TR 2SA1576A-R
			Q2234	405 092 4101	TR 2SC4081-R
			Q2236	405 092 4101	TR 2SC4081-R
			Q2237	405 092 4101	TR 2SC4081-R
			Q2401	405 129 7808	TR UMG2N
			Q2501	405 131 4505	TR 2SD1767Q
			Q2511	405 133 8907	TR DTC114EUA
			Q2512	405 133 8907	TR DTC114EUA
			Q2521	405 169 1101	TR 2SK3617
			Q2541	405 128 9605	TR 2SC2411K-Q
			OR	405 035 5905	TR 2SC2411K-R
			Q2561	405 141 0603	TR 2SA1037AK-R
			(INTEGRATED CIRCUITS)		
			IC201	410 388 5106	IC SCC0020
			IC213	409 246 9707	IC LA6358NM
Q1011	405 045 8200	(SEMICONDUCTORS) TR 2SK443-6-TB			
Q1012	405 079 6302	TR 2SC4399-5			
		(INTEGRATED CIRCUITS)			
IC102	409 446 8708	IC CXD3400N			
IC103	409 525 5901	IC AD9848AKST			
IC104	409 427 7805	IC TC74ACT32FT			
		(DIODES)			
D1001	407 113 5609	DIODE DSH015			
D1011	407 113 5609	DIODE DSH015			
		(INDUCTORS)			
L1011	645 043 5881	INDUCTOR,10U J			
L1101	645 043 5881	INDUCTOR,10U J			
L1102	645 043 5881	INDUCTOR,10U J			
L1103	645 043 5881	INDUCTOR,10U J			
L1201	645 018 9326	INDUCTOR,1000 OHM			
		(CAPACITORS)			
C1001	403 346 2309	CERAMIC 0.1U K 10V			
C1002	403 285 6406	TA-SOLID 1U M 35V			
C1003	403 381 4702	ELECT 22U M 16V			
C1004	403 164 0204	CERAMIC 0.1U Z 25V			
C1005	403 164 0204	CERAMIC 0.1U Z 25V			
C1011	403 155 1807	CERAMIC 0.01U K 25V			
C1012	403 311 7605	CERAMIC 2200P K 50V			
C1013	403 155 1807	CERAMIC 0.01U K 25V			
C1014	403 376 6902	TA-SOLID 3.3U M 25V			
C1015	403 164 0204	CERAMIC 0.1U Z 25V			
C1016	403 346 2309	CERAMIC 0.1U K 10V			
C1101	403 285 6802	TA-SOLID 10U M 6.3V			
C1102	403 346 2309	CERAMIC 0.1U K 10V			
C1103	403 285 6802	TA-SOLID 10U M 6.3V			
C1104	403 346 2309	CERAMIC 0.1U K 10V			
C1105	403 346 2309	CERAMIC 0.1U K 10V			
C1106	403 346 2309	CERAMIC 0.1U K 10V			
C1107	403 346 2309	CERAMIC 0.1U K 10V			
C1108	403 164 0204	CERAMIC 0.1U Z 25V			
C1111	403 285 6802	TA-SOLID 10U M 6.3V			
C1112	403 346 2309	CERAMIC 0.1U K 10V			
C1113	403 346 2309	CERAMIC 0.1U K 10V			
C1114	403 346 2309	CERAMIC 0.1U K 10V			
C1115	403 346 2309	CERAMIC 0.1U K 10V			
C1116	403 346 2309	CERAMIC 0.1U K 10V			
C1117	403 346 2309	CERAMIC 0.1U K 10V			
C1118	403 283 6309	CERAMIC 1U Z 10V			
C1119	403 283 6309	CERAMIC 1U Z 10V			
C1120	403 346 2309	CERAMIC 0.1U K 10V			
		(RESISTORS)			
R1001	401 224 8900	MT-GLAZE 100K JA 1/16W			
R1002	401 225 0903	MT-GLAZE 82K JA 1/16W			
R1011	401 225 1504	MT-GLAZE 3.9K JA 1/16W			
R1012	401 224 9600	MT-GLAZE 2.7K JA 1/16W			

LOCATION	PARTS NO.	DESCRIPTION	LOCATION	PARTS NO.	DESCRIPTION
IC227	409 475 2005	IC BA7664FV	C2122	403 381 4702	ELECT22U M 16V
IC235	409 246 9707	IC LA6358NM	C2123	403 164 0204	CERAMIC 0.1U Z 25V
IC238	409 320 9104	IC TC75U04FU	C2124	403 164 0204	CERAMIC 0.1U Z 25V
IC239	409 323 9002	IC TC7S04FU	C2126	403 383 7602	NP-ELECT 0.47U M 50V
IC241	410 494 0606	IC MB90F654APFV-G	C2133	403 346 2309	CERAMIC 0.1U K 10V
IC242	409 541 4803	IC BD4829G	C2134	403 285 6802	TA-SOLID 10U M 6.3V
IC243	409 479 2803	IC BR24C04F-W	C2161	403 285 3504	TA-SOLID 3.3U M 6.3V
IC251	409 506 8907	IC FA7700V	C2162	403 285 7809	TA-SOLID 0.47U M 35V
IC253	409 528 1405	IC TLV431ASNT1	C2224	403 285 7700	TA-SOLID 10U M 16V
IC254	409 528 1405	IC TLV431ASNT1	C2225	403 382 5807	ELECT100U M 10V
IC255	409 531 8507	IC MC78L12ABD	C2227	403 382 5807	ELECT100U M 10V
IC256	409 521 3703	IC BA00BC0WF	C2231	403 346 2309	CERAMIC 0.1U K 10V
		(DIODES)	C2245	403 311 7506	CERAMIC 22P J 50V
D2223	407 206 5400	ZENER DIODE UDZS8.2B	C2246	403 317 2307	CERAMIC 20P J 50V
D2224	407 206 5400	ZENER DIODE UDZS8.2B	C2247	403 311 3409	CERAMIC 0.01U K 16V
D2304	407 151 0406	VARACTOR DI HVU200A	C2253	403 311 7506	CERAMIC 22P J 50V
D2401	407 113 5609	DIODE DSH015	C2254	403 311 7506	CERAMIC 22P J 50V
D2501	407 103 0409	DIODE DBB08C	C2255	403 305 0001	TA-SOLID 10U M 10V
D2503	407 218 7409	ZENER DIODE UDZS15B	C2256	403 384 8905	ELECT220U M 25V
D2511	407 208 9703	ZENER DIODE UDZS5.6B	C2257	403 382 5807	ELECT100U M 10V
D2512	407 173 1108	PHOTO COUPLE TLP181-GB	C2258	403 382 1809	ELECT47U M 6.3V
D2521	407 231 0005	DIODE 1SR159-200	C2259	403 285 4006	TA-SOLID 4.7U M 10V
D2531	407 231 0005	DIODE 1SR159-200	C2263	403 285 5003	TA-SOLID 1U M 25V
D2533	407 207 7700	ZENER DIODE PTZ3.9B	C2268	403 346 2309	CERAMIC 0.1U K 10V
D2541	407 226 3905	DIODE RSD376	C2283	403 311 3409	CERAMIC 0.01U K 16V
OR	407 199 4909	DIODE 1SS376	C2308	403 311 3409	CERAMIC 0.01U K 16V
D2551	407 167 3101	DIODE D1FS6	C2309	403 311 3409	CERAMIC 0.01U K 16V
D2561	407 226 3905	DIODE RSD376	C2310	403 346 2309	CERAMIC 0.1U K 10V
OR	407 199 4909	DIODE 1SS376	C2311	403 285 5003	TA-SOLID 1U M 25V
D2562	407 218 7706	ZENER DIODE UDZS20B-TE17	C2313	403 384 5201	NP-ELECT 4.7U M 16V
		(OSCILLATORS)	C2315	403 346 2309	CERAMIC 0.1U K 10V
X2001	645 036 9872	OSC,CRYSTAL 17.73447MHZ	C2316	403 346 2309	CERAMIC 0.1U K 10V
X2301	645 007 6947	OSC,CRYSTAL 28.375KHZ	C2317	403 285 3603	TA-SOLID 4.7U M 6.3V
X2401	645 046 1415	OSC,CERAMIC 4.00MHZ	C2327	403 285 3603	TA-SOLID 4.7U M 6.3V
		(VARIABLE RESISTORS)	C2331	403 346 2309	CERAMIC 0.1U K 10V
VR244	645 000 0232	VR,SEMI,10K S	C2332	403 311 4505	CERAMIC 1000P K 50V
OR	645 017 2922	VR,SEMI,10K S	C2333	403 311 4505	CERAMIC 1000P K 50V
		(TRIMMER)	C2402	403 285 6802	TA-SOLID 10U M 6.3V
CT232	645 051 7655	TRIMMER,30PF	C2403	403 346 2309	CERAMIC 0.1U K 10V
		(INDUCTORS)	C2404	403 346 2309	CERAMIC 0.1U K 10V
L2001	645 043 5881	INDUCTOR,10U J	C2405	403 346 2309	CERAMIC 0.1U K 10V
L2002	645 043 5881	INDUCTOR,10U J	C2406	403 285 6802	TA-SOLID 10U M 6.3V
L2003	645 043 5881	INDUCTOR,10U J	C2500	403 379 7104	CERAMIC 1000P K 630V
L2011	645 018 9326	INDUCTOR,1000 OHM	C2501	403 377 2804	ELECT470U M 50V
L2012	645 018 9326	INDUCTOR,1000 OHM	C2504	403 070 0909	CERAMIC 0.1U K 50V
L2013	645 018 9326	INDUCTOR,1000 OHM	C2505	403 381 4603	ELECT22U M 35V
L2121	645 043 5881	INDUCTOR,10U J	C2506	403 298 9609	CERAMIC 0.1U K 16V
L2221	645 043 5881	INDUCTOR,10U J	C2509	403 379 7104	CERAMIC 1000P K 630V
L2236	645 043 7380	INDUCTOR,33U J	C2510	403 379 7104	CERAMIC 1000P K 630V
L2241	645 055 3134	INDUCTOR,68U J	C2511	403 372 4506	CERAMIC 2.2U K 25V
L2301	645 043 5881	INDUCTOR,10U J	C2512	403 189 0807	CERAMIC 0.1U K 25V
L2302	645 043 5898	INDUCTOR,47U J	C2514	403 325 6304	CERAMIC 0.22U K 10V
L2401	645 043 5881	INDUCTOR,10U J	C2521	403 376 9309	CERAMIC 0.047U K 250V
L2531	645 052 4264	INDUCTOR,100U N	C2522	403 379 2703	CERAMIC 470P J 200V
L2541	645 050 7489	INDUCTOR,100U K	C2525	403 357 3302	CERAMIC 0.01U K 630V
L2551	645 052 4264	INDUCTOR,100U N	C2532	403 333 3609	POS-SOLID 33U M 10V
L2561	645 050 7489	INDUCTOR,100U K	C2534	403 333 3609	POS-SOLID 33U M 10V
		(TRANSFORMER)	C2535	403 189 0807	CERAMIC 0.1U K 25V
T2521	△645 053 8223	TRANS,POWER,PULSE	C2536	403 298 9609	CERAMIC 0.1U K 16V
		(CAPACITORS)	C2542	403 372 4506	CERAMIC 2.2U K 25V
C2001	403 285 6802	TA-SOLID 10U M 6.3V	C2543	403 372 4506	CERAMIC 2.2U K 25V
C2002	403 346 2309	CERAMIC 0.1U K 10V	C2544	403 298 9609	CERAMIC 0.1U K 16V
C2003	403 346 2309	CERAMIC 0.1U K 10V	C2545	403 189 0807	CERAMIC 0.1U K 25V
C2004	403 346 2309	CERAMIC 0.1U K 10V	C2546	403 372 4506	CERAMIC 2.2U K 25V
C2005	403 346 2309	CERAMIC 0.1U K 10V	C2547	403 189 0807	CERAMIC 0.1U K 25V
C2006	403 346 2309	CERAMIC 0.1U K 10V	C2552	403 333 3609	POS-SOLID 33U M 10V
C2007	403 285 6802	TA-SOLID 10U M 6.3V	C2553	403 333 3609	POS-SOLID 33U M 10V
C2008	403 346 2309	CERAMIC 0.1U K 10V	C2554	403 298 9609	CERAMIC 0.1U K 16V
C2009	403 285 6802	TA-SOLID 10U M 6.3V	C2555	403 333 3609	POS-SOLID 33U M 10V
C2010	403 346 2309	CERAMIC 0.1U K 10V	C2562	403 372 4506	CERAMIC 2.2U K 25V
C2011	403 346 2309	CERAMIC 0.1U K 10V	C2563	403 372 4506	CERAMIC 2.2U K 25V
C2012	403 346 2309	CERAMIC 0.1U K 10V	C2564	403 372 4506	CERAMIC 2.2U K 25V
C2013	403 285 6802	TA-SOLID 10U M 6.3V	C2565	403 298 9609	CERAMIC 0.1U K 16V
C2014	403 346 2309	CERAMIC 0.1U K 10V			(RESISTORS)
C2015	403 346 2309	CERAMIC 0.1U K 10V	R2001	401 226 1503	MT-GLAZE 0.000 ZA 1/16W
C2016	403 346 2309	CERAMIC 0.1U K 10V	R2002	401 224 8801	MT-GLAZE 100 JA 1/16W
C2120	403 382 1908	ELECT47U M 16V	R2011	401 226 1503	MT-GLAZE 0.000 ZA 1/16W
C2121	403 164 0204	CERAMIC 0.1U Z 25V	R2012	401 226 1503	MT-GLAZE 0.000 ZA 1/16W

LOCATION	PARTS NO.	DESCRIPTION
R2013	401 226 1503	MT-GLAZE 0.000 ZA 1/16W
R2014	401 226 1503	MT-GLAZE 0.000 ZA 1/16W
R2015	401 226 1503	MT-GLAZE 0.000 ZA 1/16W
R2016	401 226 1503	MT-GLAZE 0.000 ZA 1/16W
R2017	401 226 1503	MT-GLAZE 0.000 ZA 1/16W
R2018	401 226 1503	MT-GLAZE 0.000 ZA 1/16W
R2019	401 226 1503	MT-GLAZE 0.000 ZA 1/16W
R2121	401 038 6307	MT-GLAZE 470 JA 1/10W
R2122	401 038 6307	MT-GLAZE 470 JA 1/10W
R2123	401 038 6307	MT-GLAZE 470 JA 1/10W
R2124	401 224 9402	MT-GLAZE 1.0M JA 1/16W
R2125	401 225 0507	MT-GLAZE 33K JA 1/16W
R2126	401 225 0705	MT-GLAZE 56K JA 1/16W
R2131	401 225 0606	MT-GLAZE 5.6K JA 1/16W
R2132	401 225 0101	MT-GLAZE 27K JA 1/16W
R2136	401 225 8107	MT-GLAZE 10 JA 1/16W
R2150	401 224 8900	MT-GLAZE 100K JA 1/16W
R2151	401 225 1207	MT-GLAZE 4.7K JA 1/16W
R2153	401 224 9303	MT-GLAZE 1K JA 1/16W
R2155	401 225 1207	MT-GLAZE 4.7K JA 1/16W
R2156	401 225 1207	MT-GLAZE 4.7K JA 1/16W
R2161	401 225 1207	MT-GLAZE 4.7K JA 1/16W
R2162	401 224 9303	MT-GLAZE 1K JA 1/16W
R2164	401 225 1207	MT-GLAZE 4.7K JA 1/16W
R2165	401 224 9303	MT-GLAZE 1K JA 1/16W
R2168	401 224 8900	MT-GLAZE 100K JA 1/16W
R2170	401 224 8900	MT-GLAZE 100K JA 1/16W
R2224	401 261 9601	MT-FILM 68 DD 1/16W
R2226	401 261 9601	MT-FILM 68 DD 1/16W
R2227	401 225 1603	MT-GLAZE 390 JA 1/16W
R2228	401 225 1603	MT-GLAZE 390 JA 1/16W
R2232	401 224 9303	MT-GLAZE 1K JA 1/16W
R2233	401 224 9303	MT-GLAZE 1K JA 1/16W
R2234	401 224 9907	MT-GLAZE 22K JA 1/16W
R2235	401 225 0507	MT-GLAZE 33K JA 1/16W
R2237	401 224 9303	MT-GLAZE 1K JA 1/16W
R2239	401 224 9303	MT-GLAZE 1K JA 1/16W
R2240	401 225 0200	MT-GLAZE 3.3K JA 1/16W
R2242	401 225 3805	MT-GLAZE 1.5K JA 1/16W
R2243	401 225 1405	MT-GLAZE 47K JA 1/16W
R2244	401 225 1405	MT-GLAZE 47K JA 1/16W
R2246	401 224 9303	MT-GLAZE 1K JA 1/16W
R2248	401 224 9105	MT-GLAZE 150 JA 1/16W
R2249	401 224 9105	MT-GLAZE 150 JA 1/16W
R2250	401 225 0507	MT-GLAZE 33K JA 1/16W
R2251	401 224 9907	MT-GLAZE 22K JA 1/16W
R2252	401 224 9303	MT-GLAZE 1K JA 1/16W
R2253	401 225 2006	MT-GLAZE 680 JA 1/16W
R2256	401 225 3805	MT-GLAZE 1.5K JA 1/16W
R2284	401 224 9402	MT-GLAZE 1.0M JA 1/16W
R2286	401 226 1503	MT-GLAZE 0.000 ZA 1/16W
R2311	401 224 9006	MT-GLAZE 10K JA 1/16W
R2312	401 224 8900	MT-GLAZE 100K JA 1/16W
R2313	401 225 1207	MT-GLAZE 4.7K JA 1/16W
R2314	401 229 3900	MT-GLAZE 180 JA 1/16W
R2315	401 225 1207	MT-GLAZE 4.7K JA 1/16W
R2316	401 225 1207	MT-GLAZE 4.7K JA 1/16W
R2317	401 224 9808	MT-GLAZE 220K JA 1/16W
R2336	401 234 4800	MT-GLAZE 3.3 JA 1/16W
R2339	401 224 9006	MT-GLAZE 10K JA 1/16W
R2340	401 224 8900	MT-GLAZE 100K JA 1/16W
R2341	401 224 9402	MT-GLAZE 1.0M JA 1/16W
R2401	401 226 1503	MT-GLAZE 0.000 ZA 1/16W
R2402	401 224 9006	MT-GLAZE 10K JA 1/16W
R2403	401 225 1207	MT-GLAZE 4.7K JA 1/16W
R2404	401 224 9006	MT-GLAZE 10K JA 1/16W
R2405	401 224 9006	MT-GLAZE 10K JA 1/16W
R2406	401 224 9006	MT-GLAZE 10K JA 1/16W
R2407	401 224 9006	MT-GLAZE 10K JA 1/16W
R2412	401 226 1503	MT-GLAZE 0.000 ZA 1/16W
R2414	401 226 1503	MT-GLAZE 0.000 ZA 1/16W
R2416	401 226 1503	MT-GLAZE 0.000 ZA 1/16W
R2417	401 226 1503	MT-GLAZE 0.000 ZA 1/16W
R2418	401 226 1503	MT-GLAZE 0.000 ZA 1/16W
R2423	401 226 1503	MT-GLAZE 0.000 ZA 1/16W
R2424	401 226 1503	MT-GLAZE 0.000 ZA 1/16W
R2426	401 037 5004	MT-GLAZE 0.000 ZA 1/10W
R2431	401 224 9006	MT-GLAZE 10K JA 1/16W

LOCATION	PARTS NO.	DESCRIPTION
R2432	401 224 9006	MT-GLAZE 10K JA 1/16W
R2433	401 224 9006	MT-GLAZE 10K JA 1/16W
R2435	401 226 1503	MT-GLAZE 0.000 ZA 1/16W
R2436	401 226 1503	MT-GLAZE 0.000 ZA 1/16W
R2437	401 226 1503	MT-GLAZE 0.000 ZA 1/16W
R2438	401 224 9006	MT-GLAZE 10K JA 1/16W
R2439	401 226 1503	MT-GLAZE 0.000 ZA 1/16W
R2443	401 226 1503	MT-GLAZE 0.000 ZA 1/16W
R2445	401 224 8900	MT-GLAZE 100K JA 1/16W
R2446	401 226 1503	MT-GLAZE 0.000 ZA 1/16W
R2501	401 225 0200	MT-GLAZE 3.3K JA 1/16W
R2502	401 240 9707	MT-GLAZE 820K JA 1/16W
R2511	401 224 9907	MT-GLAZE 22K JA 1/16W
R2512	401 261 8109	MT-FILM 33K DD 1/16W
R2513	401 226 1503	MT-GLAZE 0.000 ZA 1/16W
R2514	401 224 9501	MT-GLAZE 2.2K JA 1/16W
R2516	401 224 8801	MT-GLAZE 100 JA 1/16W
R2521	401 302 7207	MT-FILM 330 JE 1W
R2522	401 225 0309	MT-GLAZE 33 JA 1/16W
R2523	401 225 0200	MT-GLAZE 3.3K JA 1/16W
R2531	401 225 1801	MT-GLAZE 47 JA 1/16W
R2533	401 226 5501	MT-GLAZE 120 JA 1/16W
R2534	401 261 5306	MT-FILM 470 DU 1/16W
R2535	401 261 4309	MT-FILM 1.2K DU 1/16W
R2536	401 225 8107	MT-GLAZE 10 JA 1/16W
R2537	401 261 5108	MT-FILM 1.0K DU 1/16W
R2541	401 225 0200	MT-GLAZE 3.3K JA 1/16W
R2542	401 226 2401	MT-GLAZE 560 JA 1/16W
R2543	401 261 5108	MT-FILM 1.0K DU 1/16W
R2544	401 261 2602	MT-FILM 10K DU 1/16W
R2545	401 261 5108	MT-FILM 1.0K DU 1/16W
R2551	401 261 5108	MT-FILM 1.0K DU 1/16W
R2552	401 261 4101	MT-FILM 2.7K DU 1/16W
R2553	401 261 5900	MT-FILM 330 DU 1/16W
R2561	401 225 0200	MT-GLAZE 3.3K JA 1/16W
R2562	401 224 9303	MT-GLAZE 1K JA 1/16W
R2752	401 226 1503	MT-GLAZE 0.000 ZA 1/16W
F2301	645 006 3404	(FILTER) FILTER,EMI 470PF
F2501	△ 423 030 0800	(FUSE) FUSE 125V 2A
CN201	645 060 3129	(CONNECTORS) SOCKET,FFC 30P (N.S.P)
CN202	645 060 3112	SOCKET,FFC 24P (N.S.P)
CN211	645 003 2387	PLUG,2P (N.S.P)
CN241	645 002 3057	PLUG,7P (N.S.P)
CN251	645 026 6911	PLUG,3P (N.S.P)

COMPL PWB,CA-3

613 200 9348

LOCATION	PARTS NO.	DESCRIPTION
D3001	407 206 5400	(DIODES) ZENER DIODE UDZS8.2B
D3002	407 206 5400	ZENER DIODE UDZS8.2B
VR301	645 005 5805	(VARIABLE RESISTORS) VR,SEMI,10K S
VR302	645 005 5805	VR,SEMI,10K S
VR303	645 005 5805	VR,SEMI,10K S
S3001	645 004 1532	(SWITCH) SWITCH,DIP 1P-1TX3, MODE
CN302	645 002 3071	(CONNECTORS) PLUG,9P (N.S.P)

FLEXIBLE FLAT CABLES

W0001	645 060 2177	FLEXIBLE FLAT CABLE,CN101-CN201
W0002	645 063 4291	FLEXIBLE FLAT CABLE,CN102-CN202

CIRCUIT DIAGRAMS & PRINTED WIRING BOARDS

TABLE OF CONTENTS

OVERALL WIRING, BLOCK DIAGRAM & CIRCUIT DIAGRAMS

OVERALL WIRING	C3
OVERALL CIRCUIT BLOCK DIAGRAM	C4
IC101 & IC102 BLOCK DIAGRAMS	
CA-1 CIRCUIT	C5
CA-1 CIRCUIT WAVEFORMS	C6
IC103 & IC104 BLOCK DIAGRAMS	
CA-2 CIRCUIT WAVEFORMS	
CA-2 CIRCUIT	C7
CA-3 CIRCUIT	C12

PRINTED WIRING BOARDS (P.W.B.)

CA-1 BOARD (SIDE A & B)	C12
CA-3 BOARD (SIDE A & B)	
CA-2 BOARD (SIDE A)	C13
CA-2 BOARD (SIDE B)	C14

NOTES:

1. All resistance values in "OHMS" unless otherwise noted.
(K=1,000 ; M=1,000,000)
2. All capacitance values in "μF" unless otherwise noted.
p=pico farad ; μ ,u or U=micro farad
3. All inductance values in "μH" unless otherwise noted.
μ ,u or U=micro henry ; m=milli henry

PRODUCT SAFETY NOTICE

THE COMPONENTS DESIGNATED BY A SYMBOL () IN THIS SCHEMATIC DIAGRAM DESIGNATES COMPONENTS WHOSE VALUE ARE OF SPECIAL SIGNIFICANCE TO PRODUCT SAFETY. SHOULD ANY COMPONENT DESIGNATED BY A SYMBOL NEED TO BE REPLACED, USE ONLY THE PART DESIGNATED IN THE PARTS LIST.
DO NOT DEVIATE FROM THE RESISTANCE, WATTAGE AND VOLT-AGE RATINGS SHOWN.

EXPLANATORY NOTES (EXAMPLES)

Resistor 10K:1/16J means 10kilo ohm $\pm 5\%$, 1/16watt max.
1M:1/10K means 1mega ohm $\pm 10\%$, 1/10watt max.

Capacitor 0.047:F means 0.047micro farad, Ftype.

Electrolytic capacitor
10:16 means 10micro farad, 16volt max.

Inductor 330:J means 330micro henry $\pm 5\%$
470:K means 470micro henry $\pm 10\%$
No description J or K means $\pm 5\%$

PAL-C-EX

OVERALL WIRING, BLOCK DIAGRAM & CIRCUIT DIAGRAMS

OVERALL WIRING

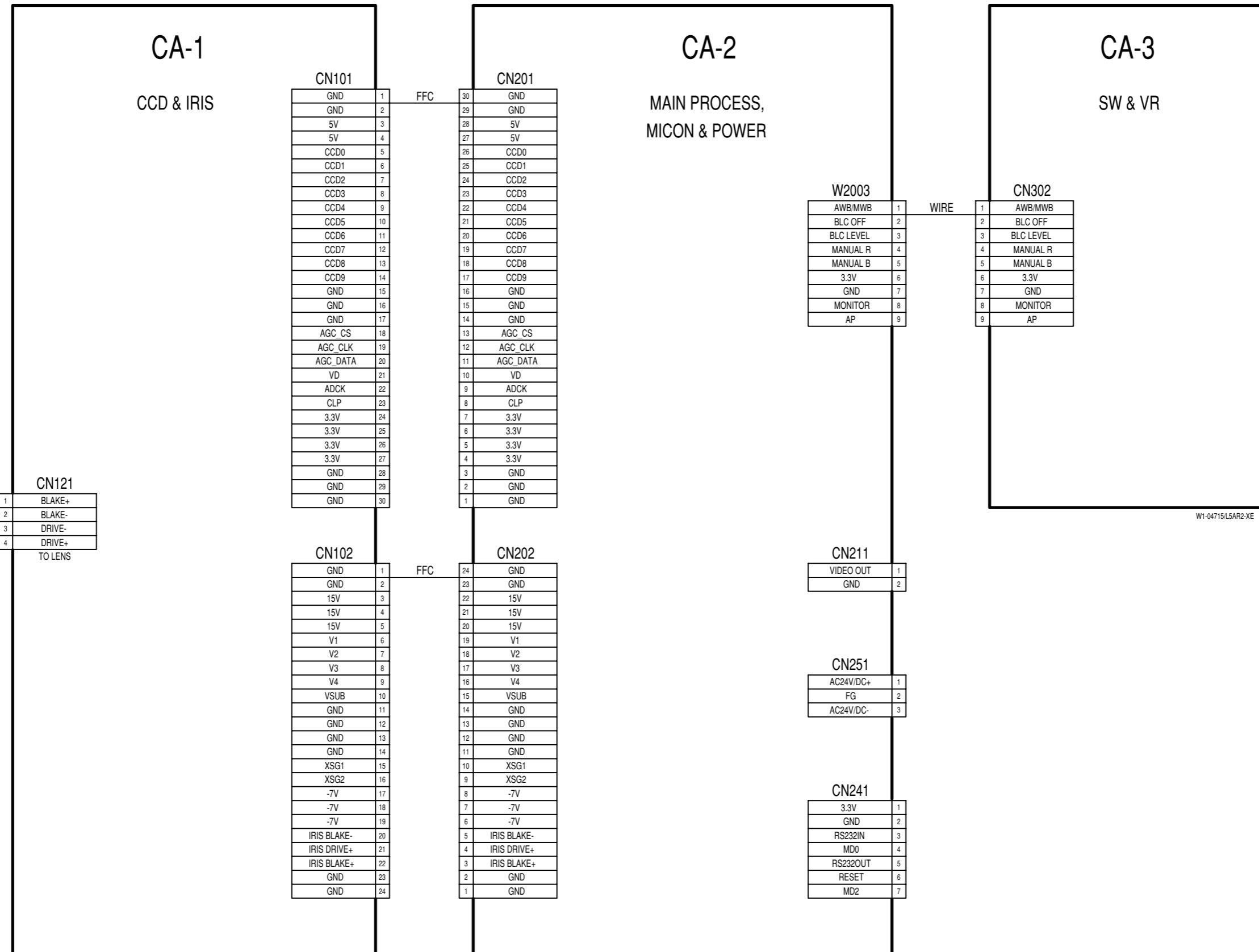

W1-04715/LSAR2-XE

OVERALL CIRCUIT BLOCK DIAGRAM

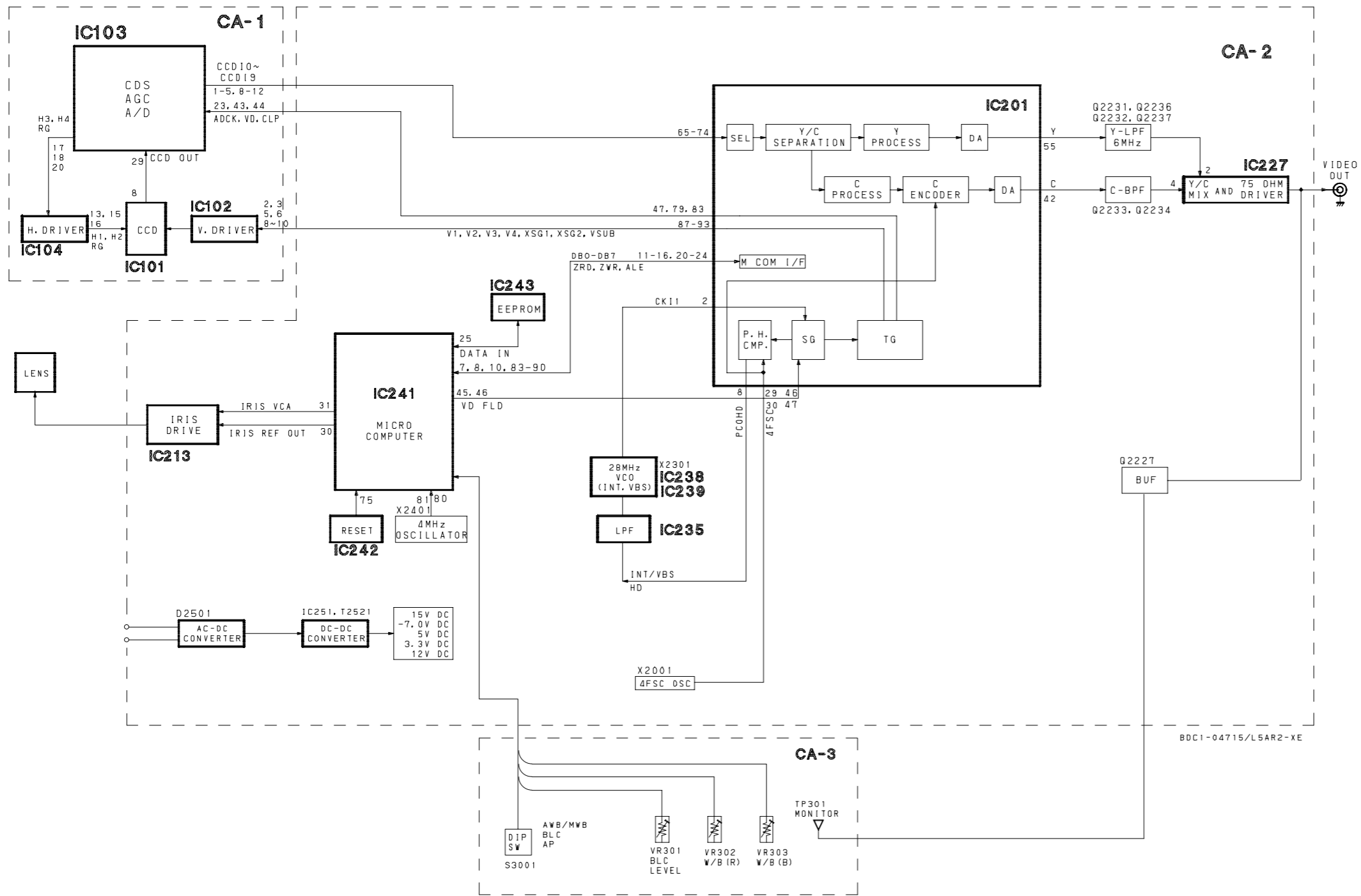

IC101 BLOCK DIAGRAM (ICX409AK)

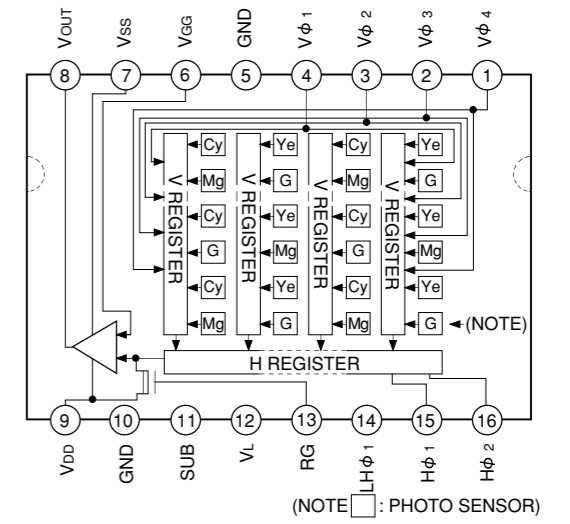

IC102 BLOCK DIAGRAM (CXD3400N)

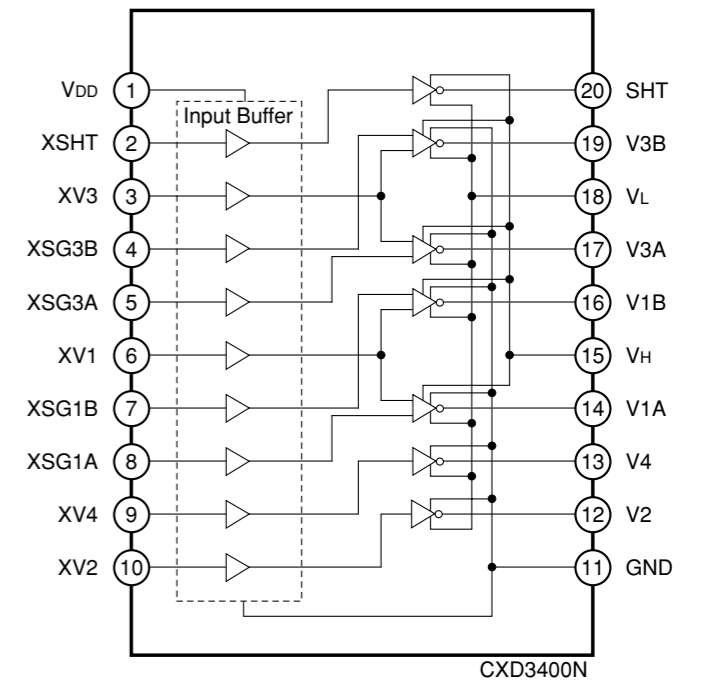

CA-1 CIRCUIT

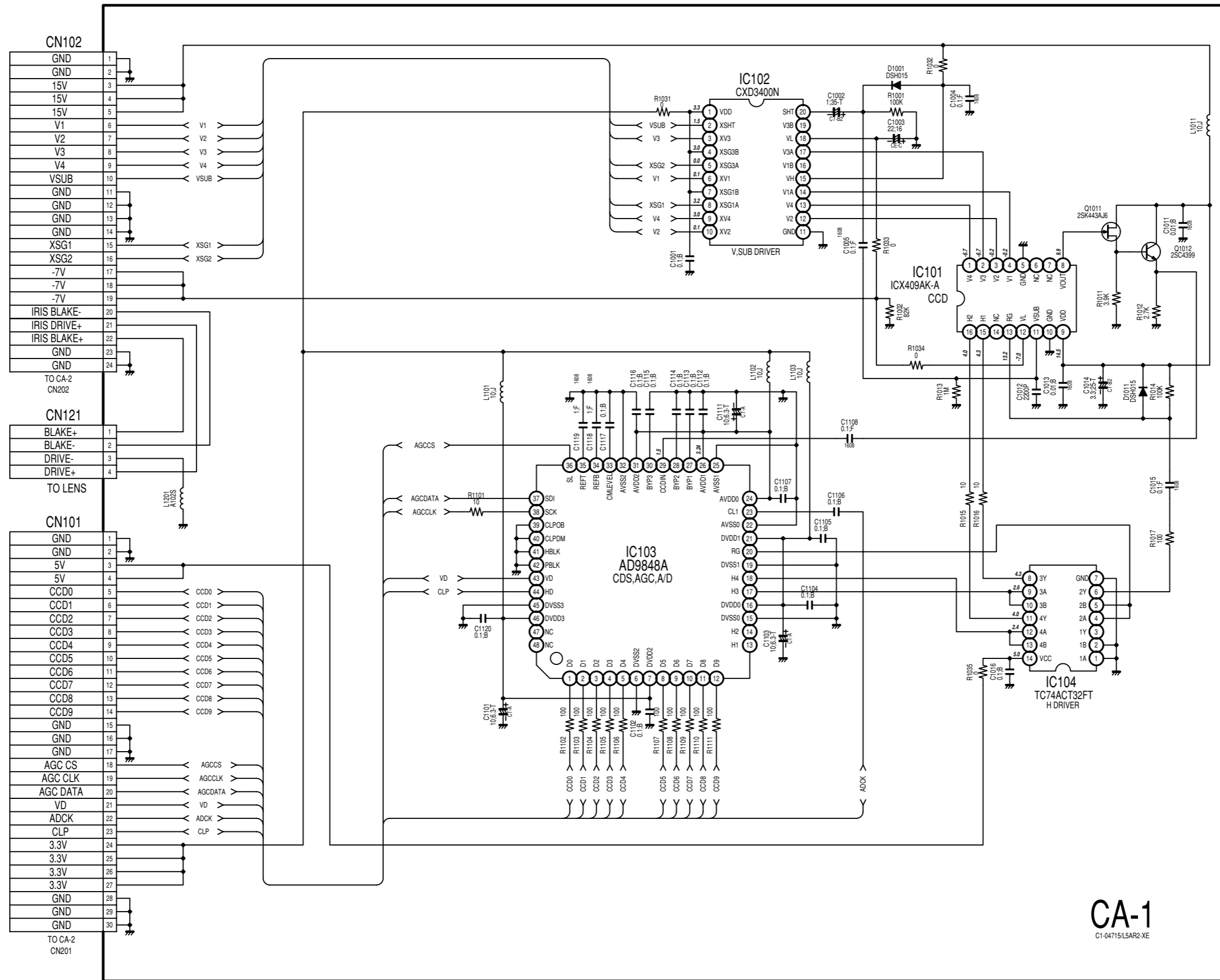

CA-1
C1-04715/L5AR2-XE

CA-1 CIRCUIT WAVEFORMS

TEST POINT LOCATION	WAVEFORM	TEST POINT LOCATION	WAVEFORM
IC101-1 2V/div 20µs/div V4		IC101-15 2V/div 50ns/div H1	
IC101-2 5V/div 20µs/div V3		IC101-16 2V/div 50ns/div H2	
IC101-3 5V/div 20µs/div V2		IC103-29 0.5V/div 10µs/div CCD IN	
IC101-4 5V/div 20µs/div V1		IC103-43 2V/div 20µs/div VD	
IC101-13 2V/div 50ns/div RG		IC103-44 2V/div 10ms/div HD	

WF-CA1-L5AR2XE

IC103 BLOCK DIAGRAM (AD9848A)

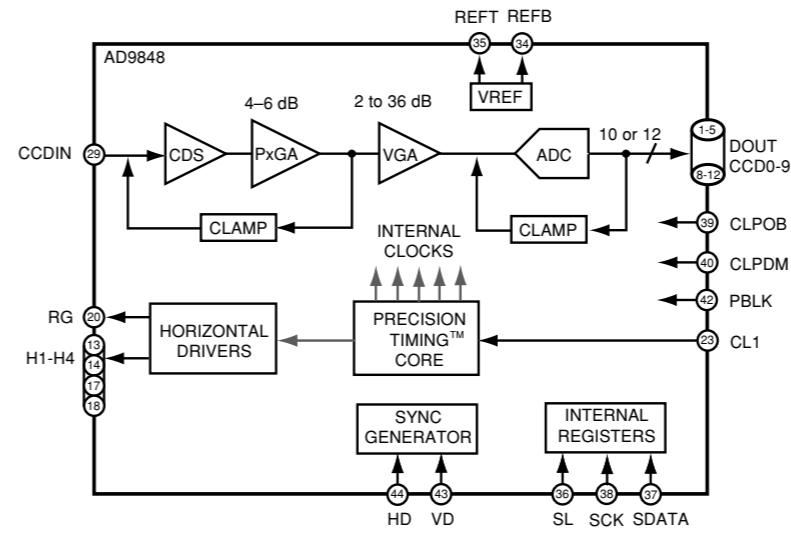

IC104 BLOCK DIAGRAM (TC74ACT32FT)

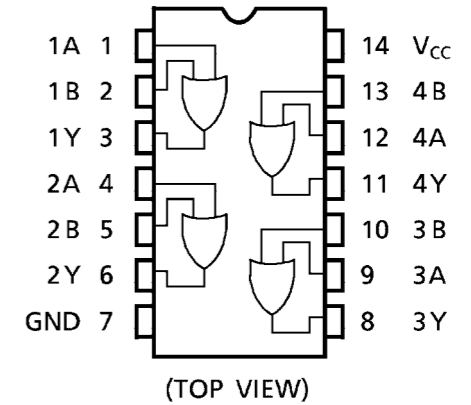

CA-2 CIRCUIT WAVEFORMS

TEST POINT LOCATION	WAVEFORM	TEST POINT LOCATION	WAVEFORM
IC201-55 200mV/div 10µs/div YA OUT		IC201-47 1V/div 5ms/div VD	
IC201-42 200mV/div 10µs/div CA OUT		IC201-79 1V/div 50ns/div ADCK	

WF-CA2-L5AR2XE

CA-2 CIRCUIT

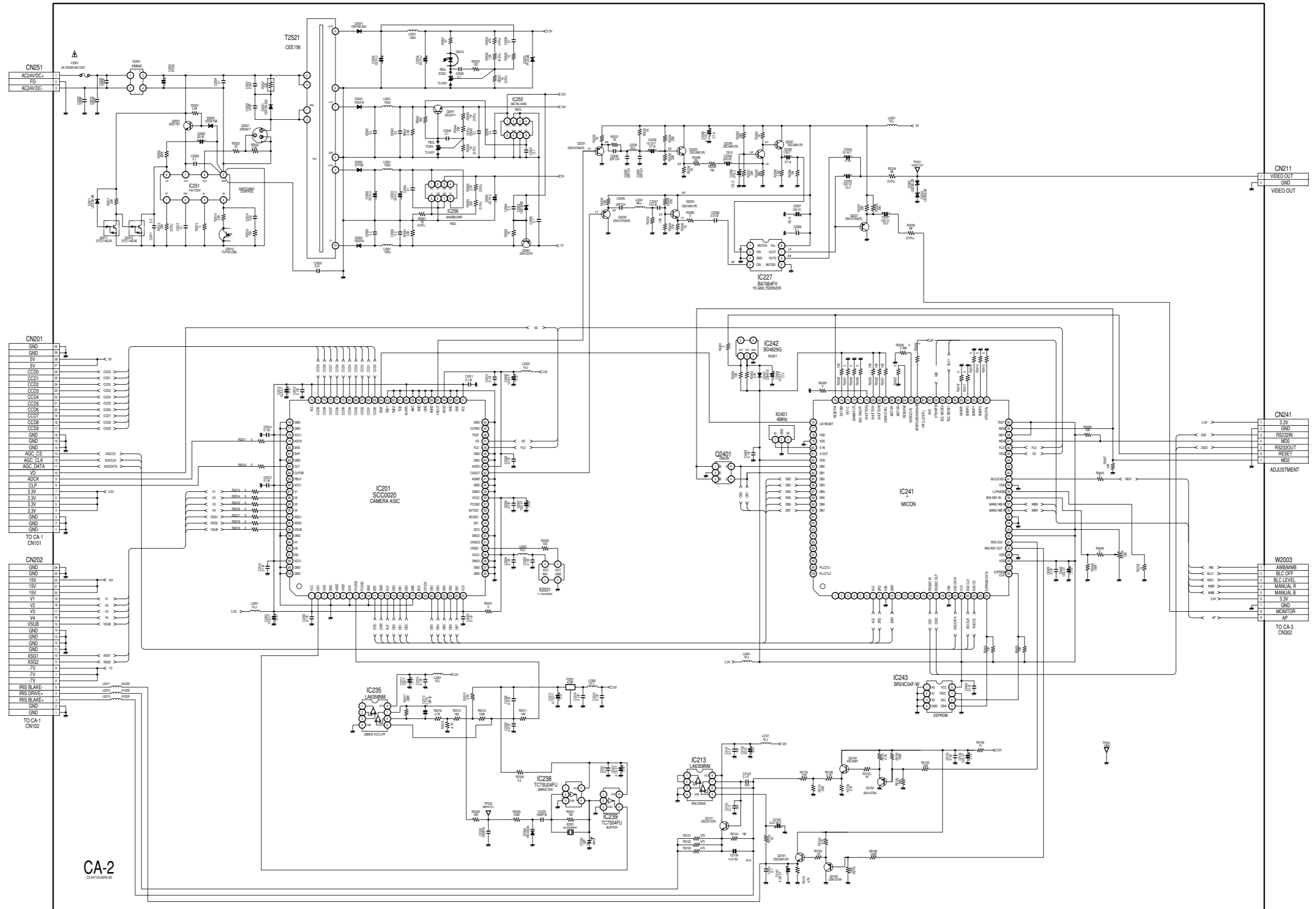

CA-2
C2 04715A0000 RE

CA-2 CIRCUIT [UPPER-LEFT]

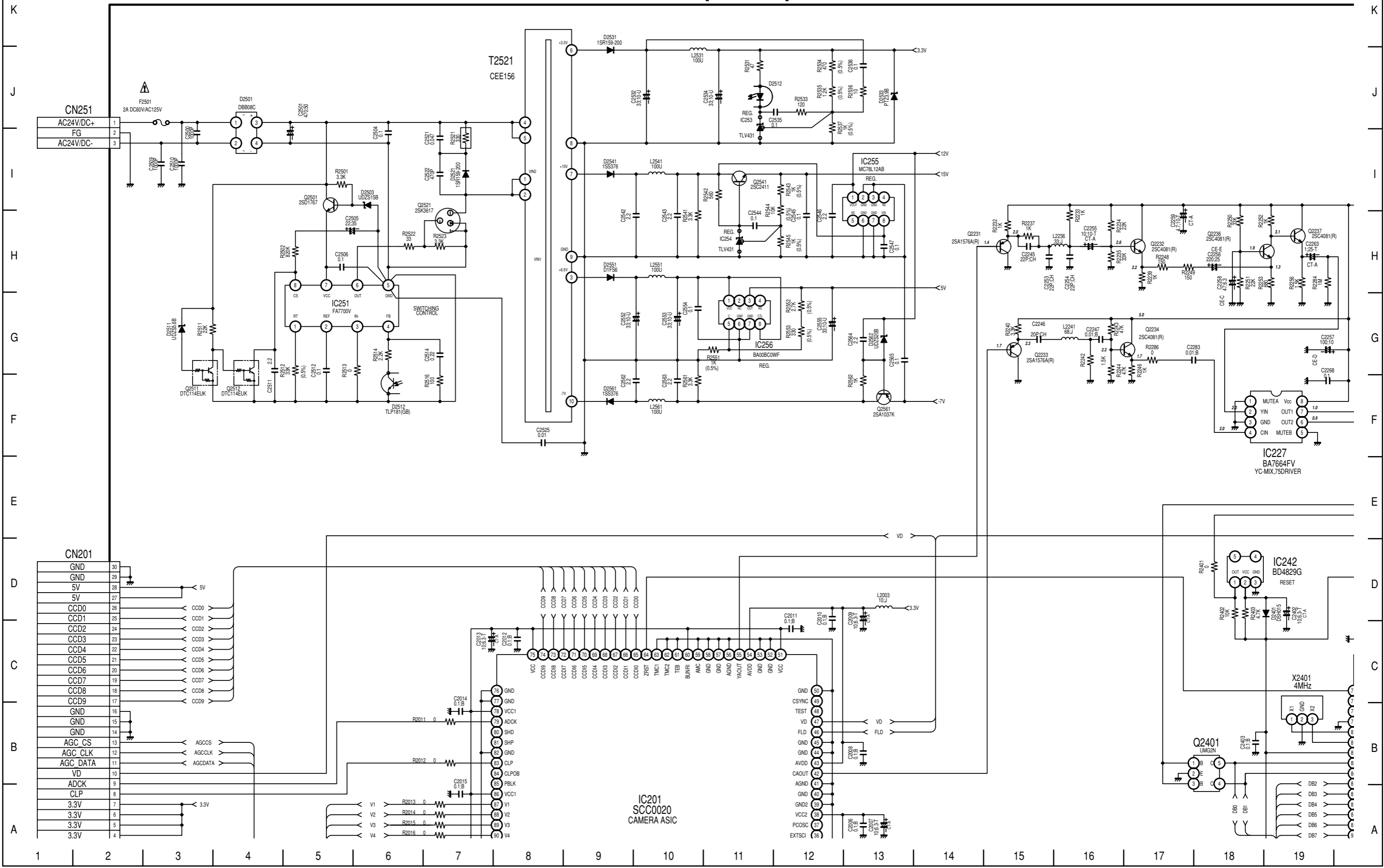

CA-2 CIRCUIT [UPPER-RIGHT]

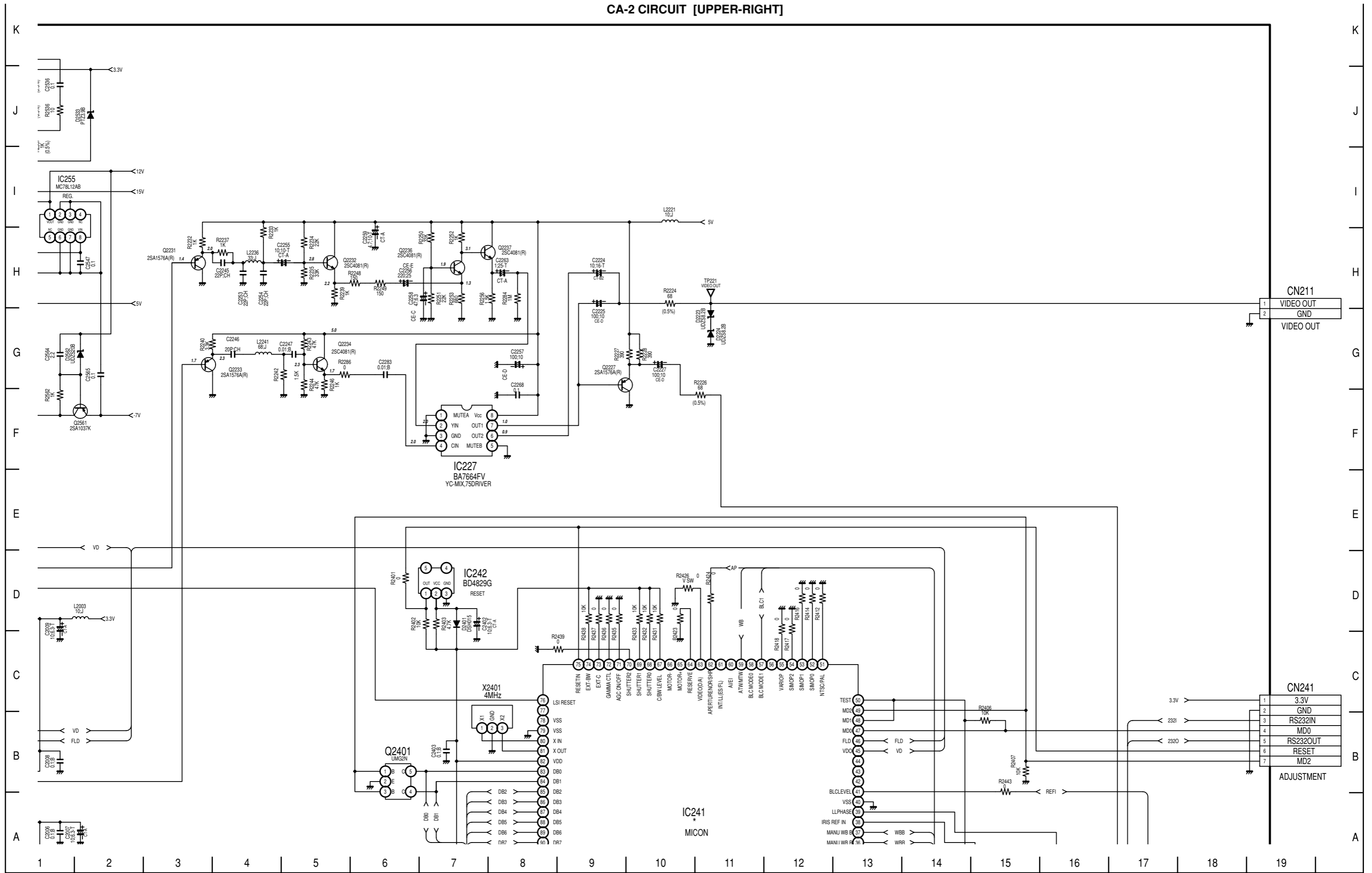

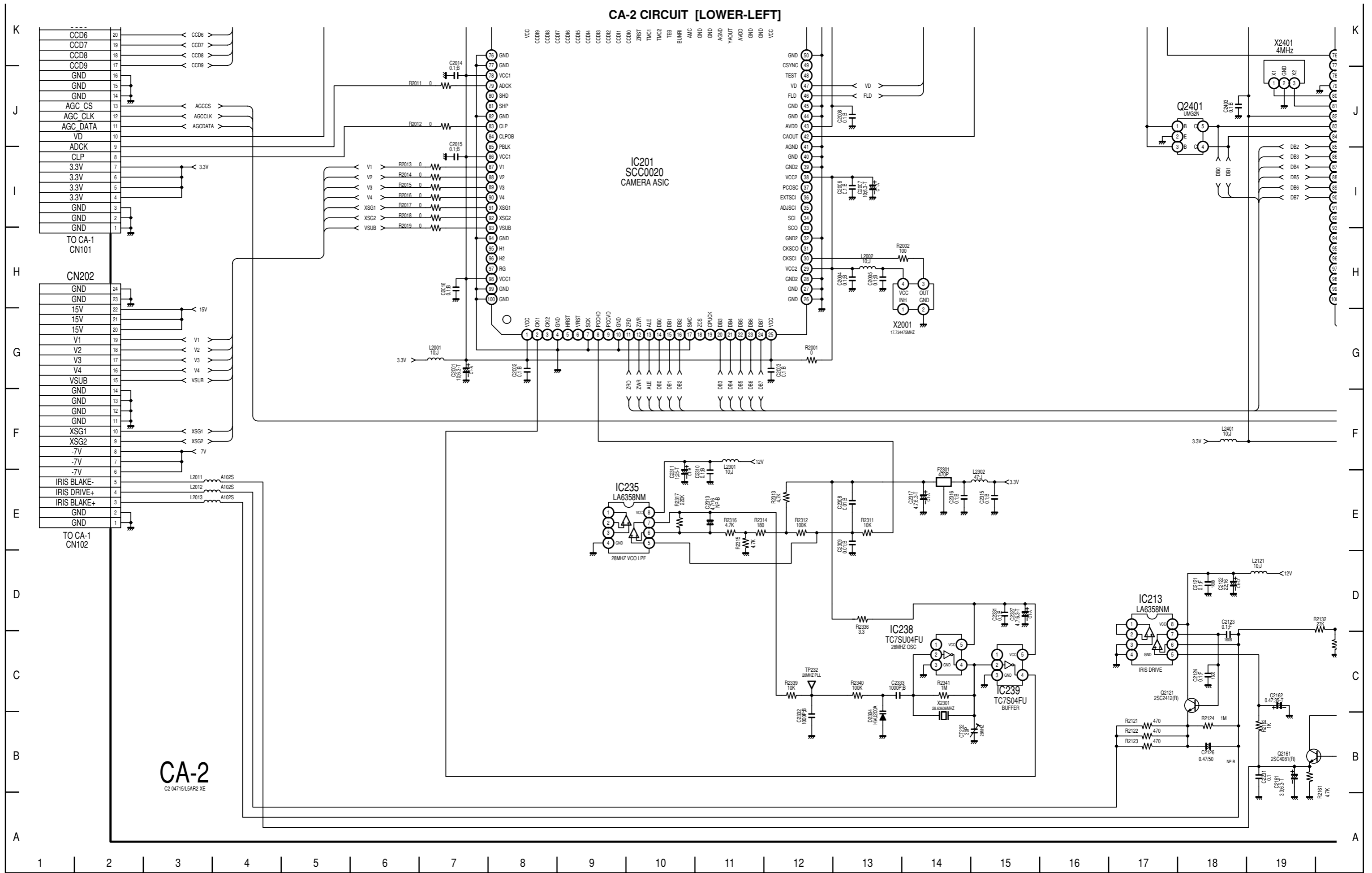

CA-2 CIRCUIT [LOWER-RIGHT]

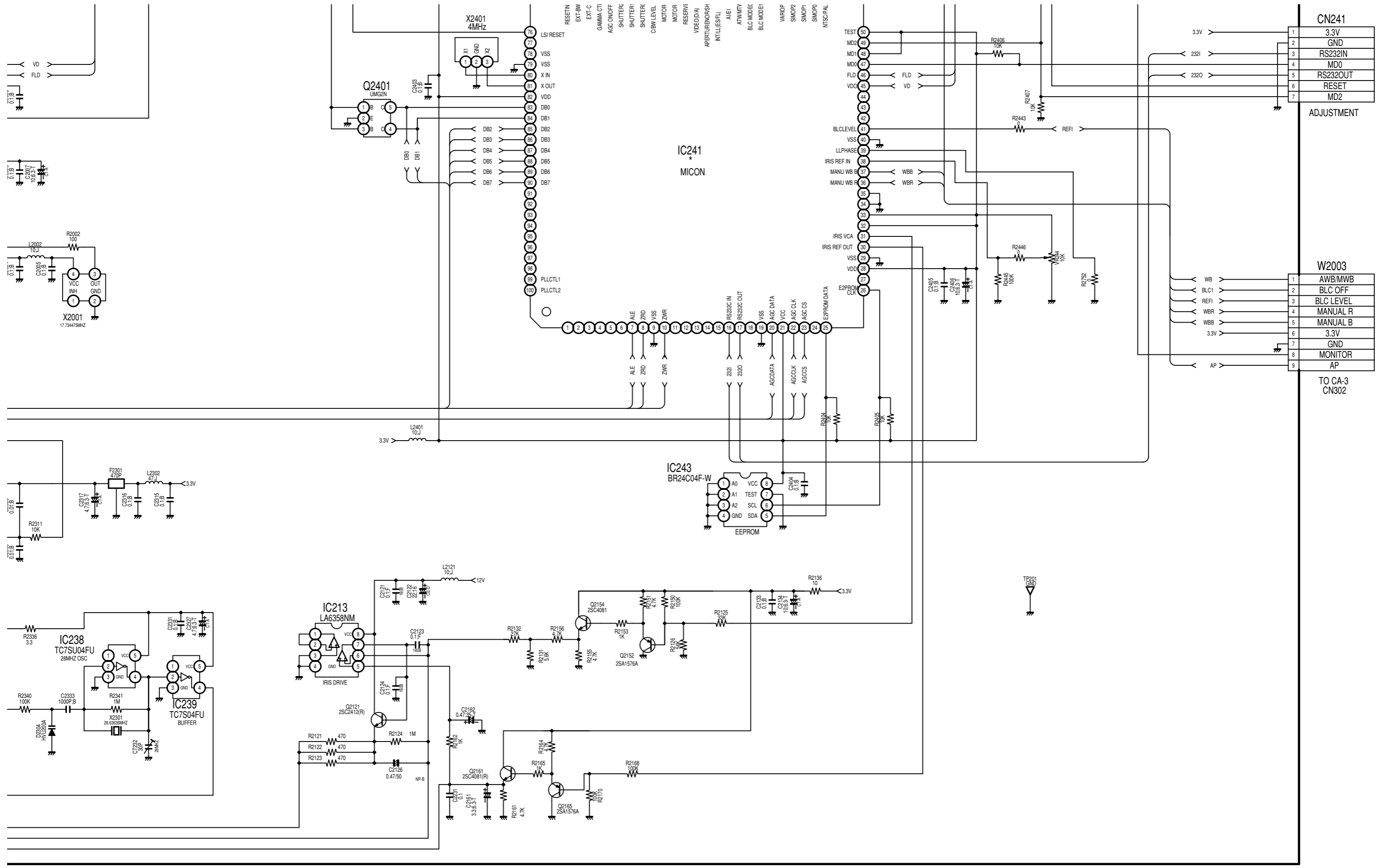

CN241

1	3.3V
2	GND
3	RS232IN
4	MD0
5	RS232OUT
6	RESET
7	MD2

ADJUSTMENT

W2003

1	AWB/MWB
2	BLC OFF
3	BLC LEVEL
4	MANUAL R
5	MANUAL B
6	3.3V
7	GND
8	MONITOR
9	AP

TO CA-3
CN302

PRINTED WIRING BOARDS (P.W.B.)

CA-3 CIRCUIT

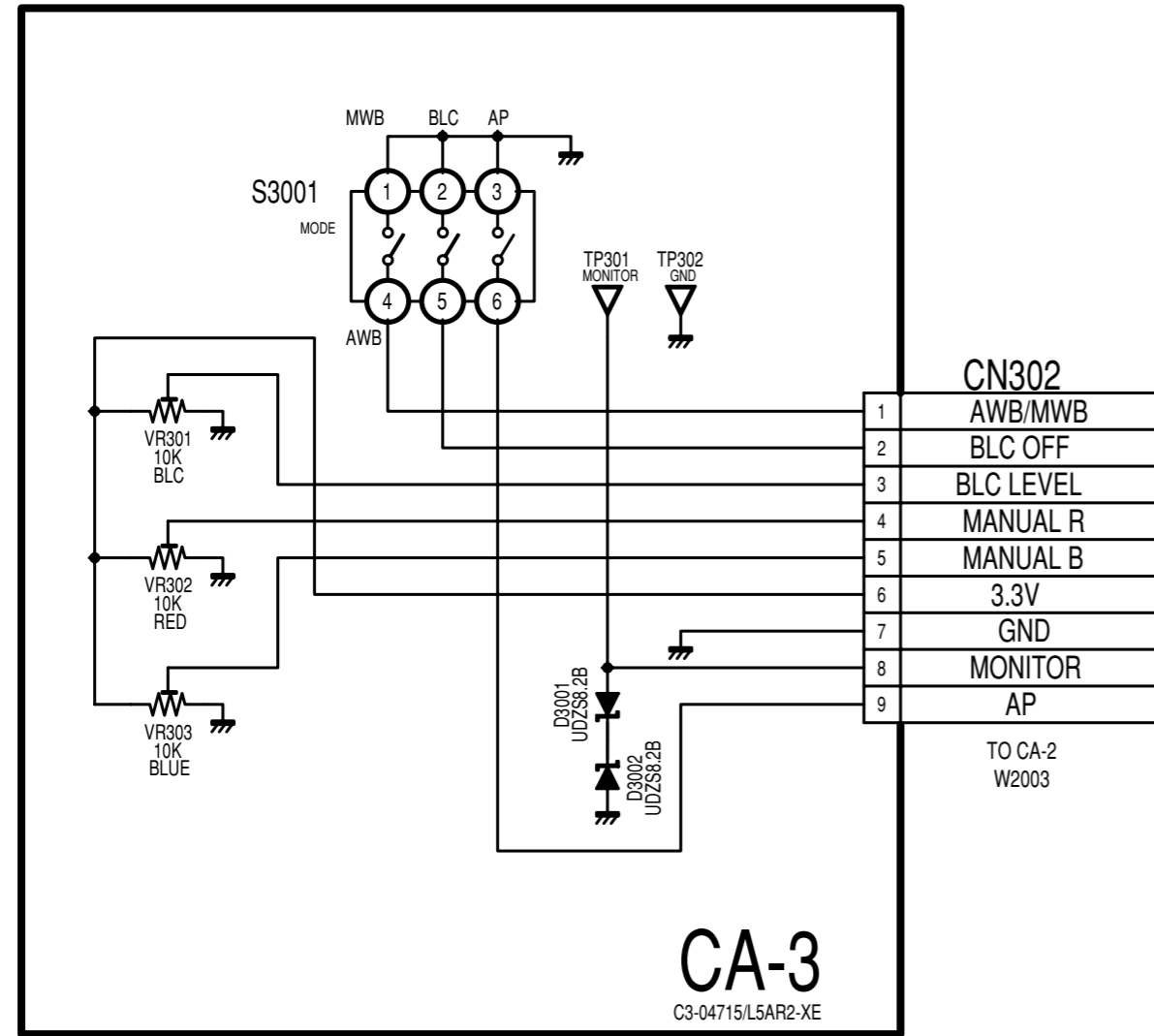

CN302	
1	AWB/MWB
2	BLC OFF
3	BLC LEVEL
4	MANUAL R
5	MANUAL B
6	3.3V
7	GND
8	MONITOR
9	AP

TO CA-2
W2003

CA-3
C3-04715/L5AR2-XE

CA-1 BOARD (SIDE A)

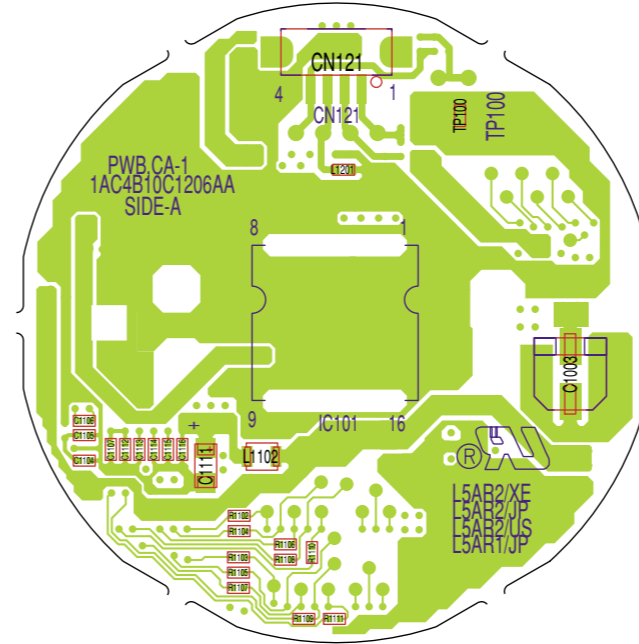

CA-1 BOARD (SIDE B)

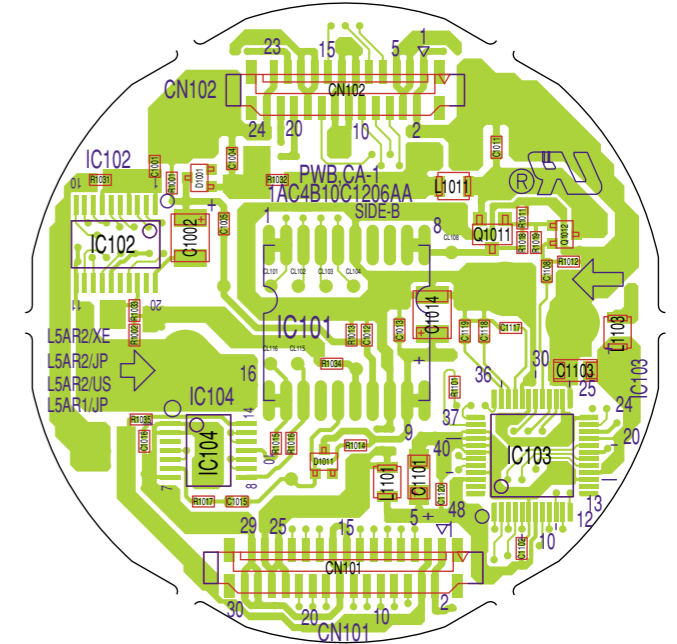

CA-3 BOARD (SIDE A)

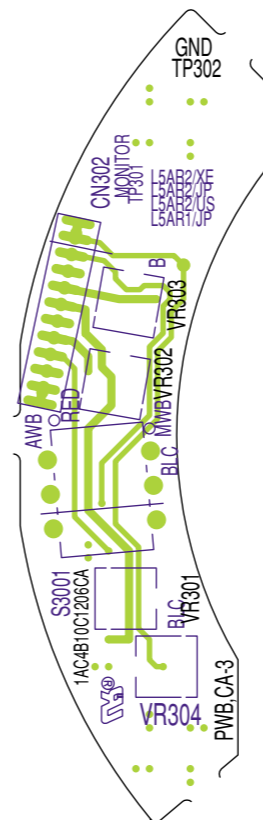

CA-3 BOARD (SIDE B)

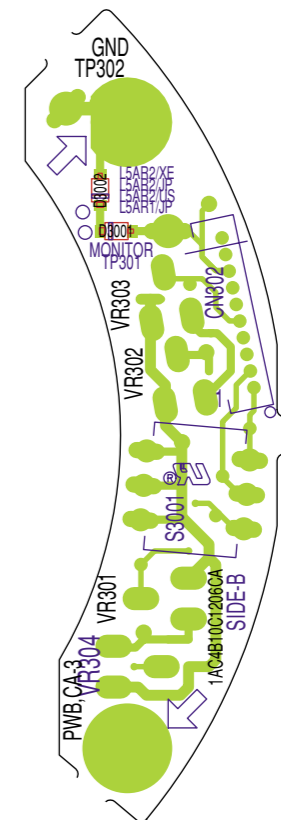

CA-2 BOARD (SIDE A)

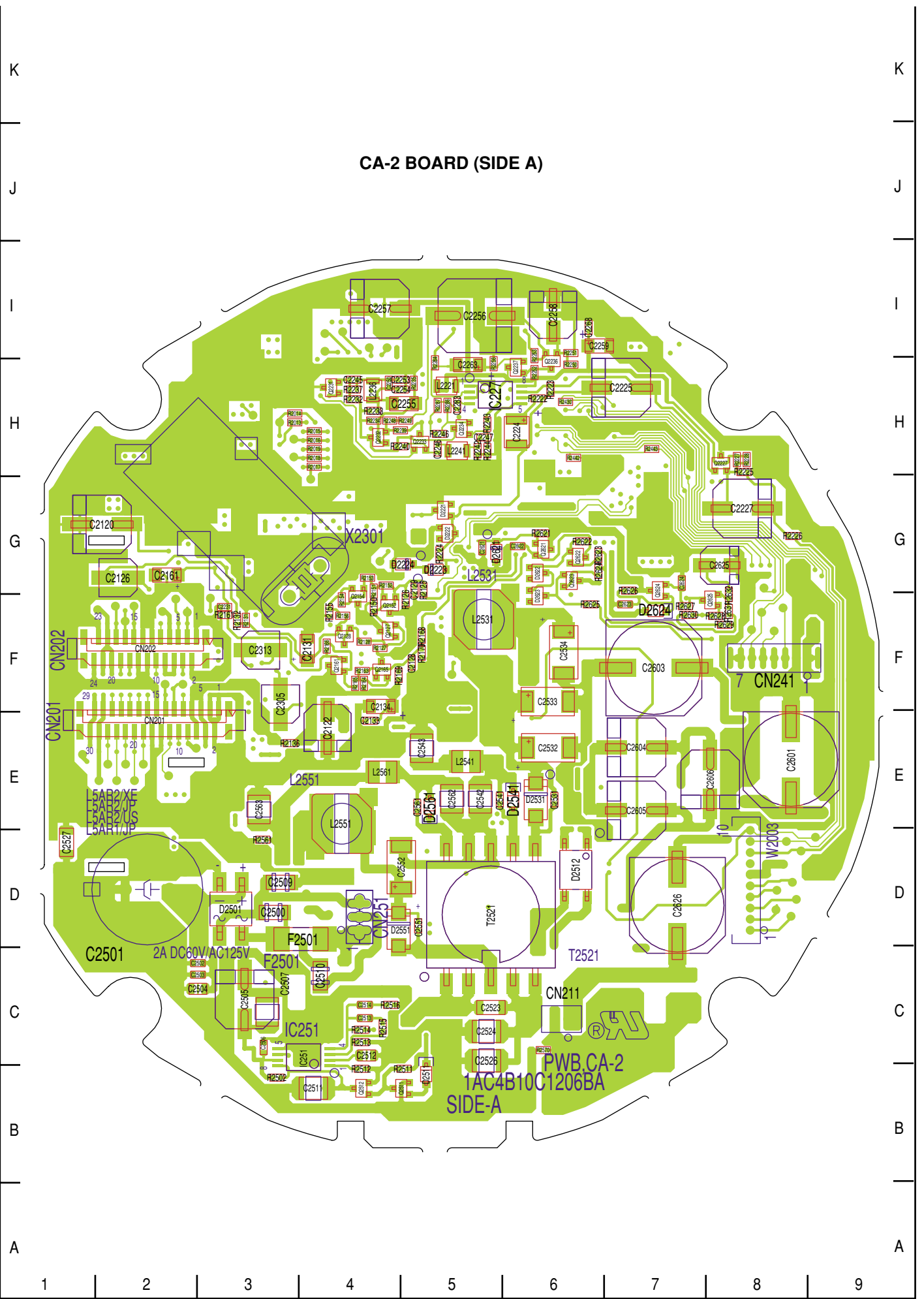

CA-2 BOARD (SIDE B)

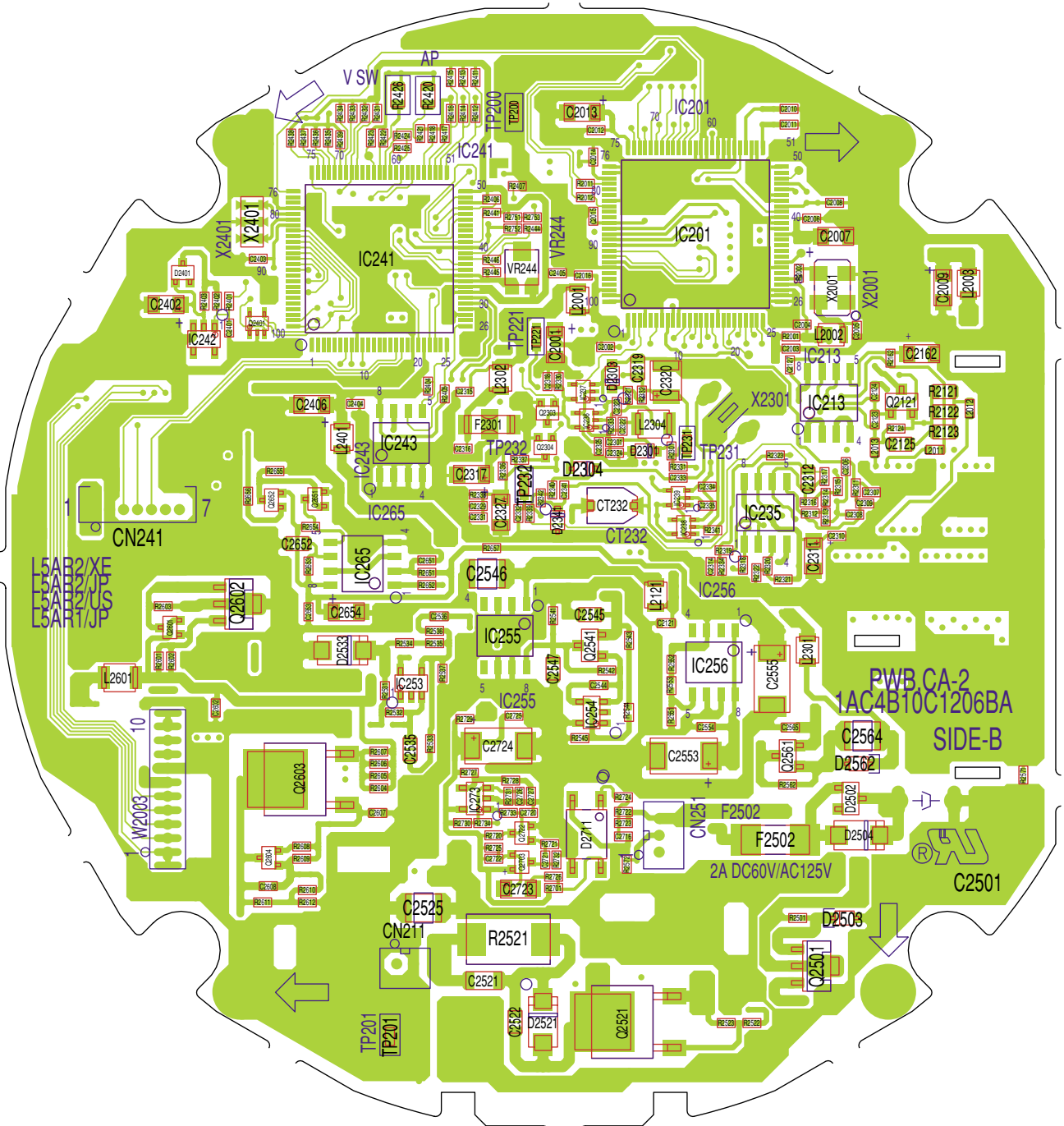



SANYO Electric Co., Ltd.
Osaka, Japan